

USER'S GUIDE



Digital Barometers with Serial Output PTB210 Series



PUBLISHED BY

Vaisala Oyj
P.O. Box 26
FIN-00421 Helsinki
Finland

Phone (int.): +358 9 8949 1
Fax: +358 9 8949 2227

Visit our Internet pages at <http://www.vaisala.com/>

© Vaisala 2008

No part of this manual may be reproduced in any form or by any means, electronic or mechanical (including photocopying), nor may its contents be communicated to a third party without prior written permission of the copyright holder.

The contents are subject to change without prior notice.

Please observe that this manual does not create any legally binding obligations for Vaisala towards the customer or end user. All legally binding commitments and agreements are included exclusively in the applicable supply contract or Conditions of Sale.

Table of Contents

CHAPTER 1	
GENERAL INFORMATION	3
Safety	3
Feedback	3
Recycling	4
Trademarks	4
License Agreement	4
Warranty	5
CHAPTER 2	
PRODUCT DESCRIPTION	7
CHAPTER 3	
INSTALLATION	9
Mounting	9
Static Pressure Head	10
Connections	11
RS232C	11
RS485	11
RS232C/TTL	12
CHAPTER 4	
OPERATING	13
General	13
Settings	14
.BAUD Setting the Baud Rate	14
Setting the Serial Communication Parameters	14
.ID Setting a Identification Code	15
Setting Pressure Limits	15
.MPM Measurements per Minute	16
.AVRG Defining the Averaging	16
.PD Setting the Instrument to Power Down State	16
Operating Commands	17
.P Outputting One Single Message	17
.BP Continuous Outputting	17
.UNIT Selecting a Pressure Unit	17
Output with or without the Unit	18
.RESET Resetting the Instrument	18
Setting the Pressure Corrections On/Off	18
.CALD Setting the Calibration Date	19
Setting the RS485 Terminating Resistor On/Off	19
Self-Testing	20
.? Basic Information of the Barometer Settings	20

CHAPTER 5
CALIBRATION AND ADJUSTMENT **21**
 Wizard Software..... **22**
 Operation..... 22

CHAPTER 6
TECHNICAL DATA **25**
 Technical Specification..... **25**
 Operating Range 25
 Accuracy 25
 General 26
 Electromagnetic Compatibility 27
 Dimensions (mm/inch) **28**

List of Figures

Figure 1 PTB210 and the Standard Accessories 7
 Figure 2 The BAROCAP® Pressure Sensor 8
 Figure 3 Different Mounting Options of the PTB210..... 9
 Figure 4 Recommended Cable Position 10

List of Tables

Table 1 Connections of the PTB210 Barometer with RS232C Interface. 11
 Table 2 Connections of the PTB210 Barometer with RS485/RS232C
 Interface 11
 Table 3 Connections of the PTB210 Barometer with RS232C/TTL
 Interface 12

CHAPTER 1

GENERAL INFORMATION

Safety

Throughout the manual, important safety considerations are highlighted as follows:

WARNING

Warning alerts you to a serious hazard. If you do not read and follow instructions very carefully at this point, there is a risk of injury or even death.

CAUTION

Caution warns you of a potential hazard. If you do not read and follow instructions carefully at this point, the product could be damaged or important data could be lost.

NOTE

Note highlights important information on using the product.

Feedback

Vaisala Customer Documentation Team welcomes your comments and suggestions on the quality and usefulness of this publication. If you find errors or have other suggestions for improvement, please indicate the chapter, section, and page number. You can send comments to us by e-mail: manuals@vaisala.com

Recycling



Recycle all applicable material.



Dispose of batteries and the unit according to statutory regulations.
Do not dispose of with regular household refuse.

Trademarks

BAROCAP[®] is a registered trademark of Vaisala.

License Agreement

All rights to any software are held by Vaisala or third parties. The customer is allowed to use the software only to the extent that is provided by the applicable supply contract or Software License Agreement.

Warranty

Vaisala hereby represents and warrants all Products manufactured by Vaisala and sold hereunder to be free from defects in workmanship or material during a period of twelve (12) months from the date of delivery save for products for which a special warranty is given. If any Product proves however to be defective in workmanship or material within the period herein provided Vaisala undertakes to the exclusion of any other remedy to repair or at its own option replace the defective Product or part thereof free of charge and otherwise on the same conditions as for the original Product or part without extension to original warranty time. Defective parts replaced in accordance with this clause shall be placed at the disposal of Vaisala.

Vaisala also warrants the quality of all repair and service works performed by its employees to products sold by it. In case the repair or service works should appear inadequate or faulty and should this cause malfunction or nonfunction of the product to which the service was performed Vaisala shall at its free option either repair or have repaired or replace the product in question. The working hours used by employees of Vaisala for such repair or replacement shall be free of charge to the client. This service warranty shall be valid for a period of six (6) months from the date the service measures were completed.

This warranty is however subject to following conditions:

- a) A substantiated written claim as to any alleged defects shall have been received by Vaisala within thirty (30) days after the defect or fault became known or occurred, and
- b) The allegedly defective Product or part shall, should Vaisala so require, be sent to the works of Vaisala or to such other place as Vaisala may indicate in writing, freight and insurance prepaid and properly packed and labelled, unless Vaisala agrees to inspect and repair the Product or replace it on site.

This warranty does not however apply when the defect has been caused through

- a) normal wear and tear or accident;
- b) misuse or other unsuitable or unauthorized use of the Product or negligence or error in storing, maintaining or in handling the Product or any equipment thereof;
- c) wrong installation or assembly or failure to service the Product or otherwise follow Vaisala's service instructions including any repairs or installation or assembly or service made by unauthorized personnel not approved by Vaisala or replacements with parts not manufactured or supplied by Vaisala;
- d) modifications or changes of the Product as well as any adding to it without Vaisala's prior authorization;
- e) other factors depending on the Customer or a third party.

Notwithstanding the aforesaid Vaisala's liability under this clause shall not apply to any defects arising out of materials, designs or instructions provided by the Customer.

This warranty is expressly in lieu of and excludes all other conditions, warranties and liabilities, express or implied, whether under law, statute or otherwise, including without limitation any implied warranties of merchantability or fitness for a particular purpose and all other obligations and liabilities of Vaisala or its representatives with respect to any defect or deficiency applicable to or resulting directly or indirectly from the Products supplied hereunder, which obligations and liabilities are hereby expressly cancelled and waived. Vaisala's liability shall under no circumstances exceed the invoice price of any Product for which a warranty claim is made, nor shall Vaisala in any circumstances be liable for lost profits or other consequential loss whether direct or indirect or for special damages.

This page intentionally left blank.

CHAPTER 2

PRODUCT DESCRIPTION

The PTB210 series digital barometers are designed for various pressure ranges. The barometers with serial output are available with two basic configurations: serial output for 500 ... 1100 hPa and 50 ... 1100 hPa. The PTB210 barometers are also available with an analog output with different scalings.

The PTB210 series barometers offer an excellent solution for outdoor installations. They operate in a wide temperature range. The housing of the barometer electronics provides an IP65 standardized protection against sprayed water. The rugged corrosion-resistant housing in combination with the small size facilitates easy installation and a long lifetime for the barometer.

All the barometers are digitally adjusted and calibrated by using electronic working standards. For the pressure range 500 ... 1100 hPa also a higher accuracy barometer is available, which is fine-tuned and calibrated against a dead-weight tester.

This manual gives the instructions for the use of PTB210 barometers with the digital output.

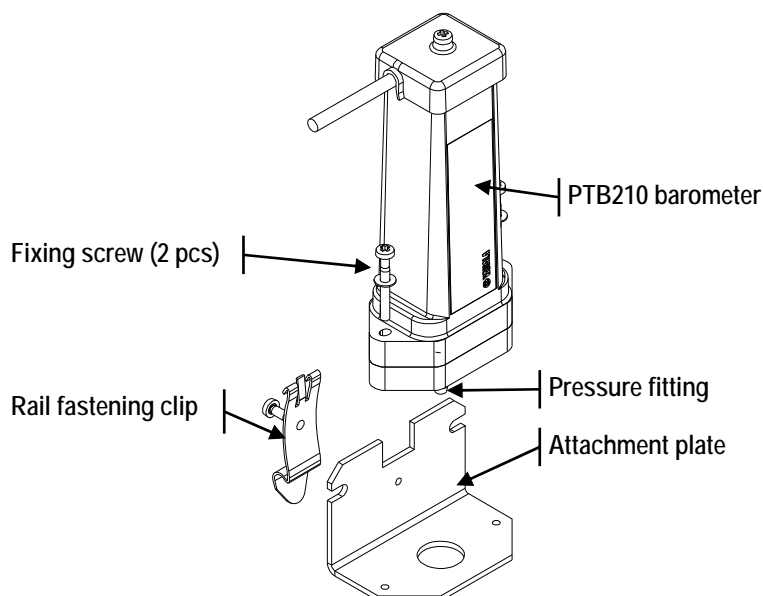

Figure 1 PTB210 and the Standard Accessories

The PTB210 barometers incorporate the BAROCAP® silicon capacitive absolute pressure sensor developed by Vaisala. The sensor features excellent hysteresis and repeatability characteristics and has an outstanding temperature and long-term stability.

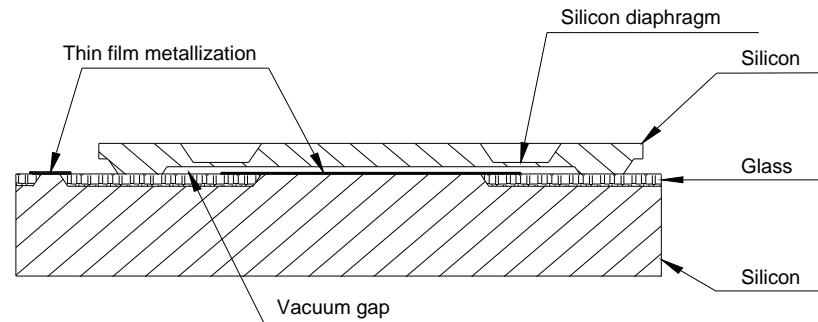

Figure 2 The BAROCAP® Pressure Sensor

The BAROCAP® pressure sensor consists of two layers of single crystal silicon having a layer of glass between them. The thinner silicon layer creates an integrated vacuum reference chamber, and forms a pressure-sensitive silicon diaphragm. The thicker silicon layer is the rigid base plate of the sensor, and it is clad with a glass dielectric. Thin film metallization has been deposited to form a capacitor electrode inside the vacuum reference chamber. The other electrode is the pressure-sensitive silicon diaphragm.

The coefficients of thermal expansion of silicon and glass materials used in the BAROCAP® pressure sensor are carefully matched together to minimize the temperature dependence, and to maximize the long-term stability. The BAROCAP® pressure sensor is designed to achieve zero temperature dependence at 1000 hPa, and its long-term stability has been maximized by thermal ageing at an elevated temperature.

CHAPTER 3

INSTALLATION

Mounting

Due to the compact design of the PTB210, all you need to do is to mount the instrument, and to connect the wires. Use one of the following three mounting options.

- Remove the pressure fitting, and place the barometer on a desired structure. Then, fix it with the slot headed screws the O-ring sealing the attachment (A).
- Fix the supplied attachment plate to a desired place. Then, attach the barometer on the plate with the screws supplied (B).
- The PTB210 can also be placed to a standard rail (DIN 35) by using the attachment plate and clip (B). Fasten the clip and barometer to the plate with the screws supplied. Finally, attach the clip to the rail.

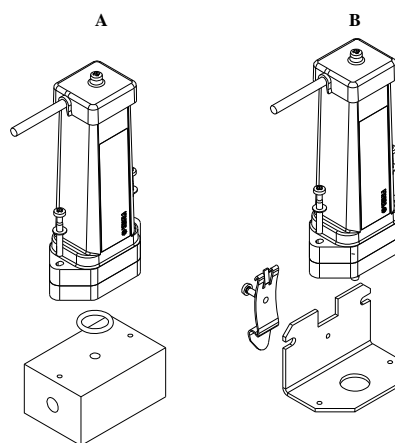

Figure 3 Different Mounting Options of the PTB210

NOTE

Always place the barometer so that the pressure fitting is downwards.

NOTE

Check that the cable is not taken upwards from the barometer. This is to prevent water flowing along the cable, and gathering close to the feed-through.

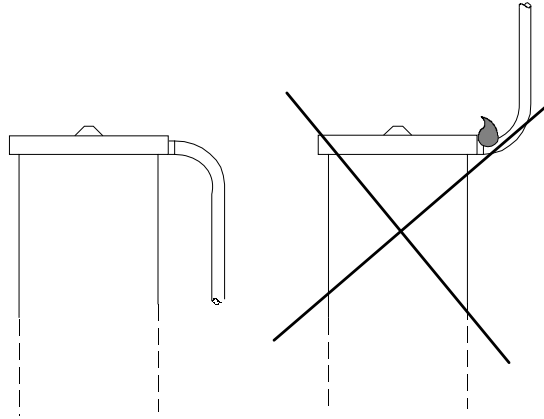

Figure 4 Recommended Cable Position

The IP65-classified housing enables the barometer to be mounted outdoors without any additional protection. However, please take care that rainwater cannot plug the open pressure fitting. In such conditions, it is recommended to connect a piece of a tube with inner diameter of 4 mm or more to the fitting. It is also possible to use a static pressure head, SPH10/20, which protects the pressure channel from rain, and minimizes the effect of wind.

Static Pressure Head

Please note that the pressure fitting supplied with the transmitter is not a static pressure head, and that the transmitter cannot be used successfully as such in turbulent or high-speed static wind conditions. In demanding wind conditions, it is recommended to use Vaisala's static pressure head, SPH10/20, to which the PTB210 digital barometers can be directly integrated. This combination provides for accurate measurement in all wind conditions.

Connections

There are three different serial output interfaces available with the PTB210 digital barometers: RS232C, RS485/232C, and RS232C/TTL. The connections depend on the output protocol in use. In following tables there are presented the connections of these output interfaces.

RS232C

Table 1 Connections of the PTB210 Barometer with RS232C Interface.

Wire color	Signal
Grey	RX
Green	TX
Blue	Ground
Pink	Supply voltage (5 ... 28 VDC)
Brown	not connected
White	not connected
Yellow	External power control (TTL level: 1 = 5 V= off, 0 = 0 V= on)

It is recommended to isolate the free wire ends.

RS485

Table 2 Connections of the PTB210 Barometer with RS485/RS232C Interface

Wire color	Signal
Grey	RX (with RS232C)
Green	TX (with RS232C)
Blue	Ground
Pink	Supply voltage (8 ... 18 VDC)
Brown	RS485 -
White	RS485 +
Yellow	External power control (TTL level: 1 = off, 0 = on)

See also chapter "Setting the RS485 Terminating Resistor On/Off " on page 19.

NOTE

The two output protocols cannot be used simultaneously. Connect either RX/TX or RS485 wires. It is recommended to isolate the free wire ends.

RS232C/TTL

Table 3 **Connections of the PTB210 Barometer with
RS232C/TTL Interface**

Wire color	Signal
Grey	RX (with RS232C)
Green	TX (with RS232C)
Blue	Ground
Pink	Supply voltage (5 ... 28 VDC)
Brown	RXD (TTL level)
White	TXD (TTL level)
Yellow	External power control (TTL level: 1 = off, 0 = on)

NOTE

The two output protocols cannot be used simultaneously. Connect either RX/TX or RXD/TXD wires. It is recommended to isolate the free wire ends.

CHAPTER 4

OPERATING

General

The PTB210 series barometers can be operated through a serial line by using suitable terminal software like Windows[®] Hyper Terminal, and the commands given in following pages.

The format of the commands is:

.ZZZ.xxx<cr>, where *ZZZ* defines an event and *xxx* is the given value of a parameter.

When there are several barometers on same line, it is necessary to use an instrument-specific identification code in front of the command e.g. 123.BAUD.9600<cr>, where 123 is the ID-code (see page 15). The code directs the command to that specific instrument. This prevents any inconsistency between the barometers and the host system. A barometer reacts only to a command with its ID, or the one that is given without the code.

Common setting commands can be given without the ID code i.e. settings are given to all barometers simultaneously.

NOTE

The barometer does not echo the given commands nor confirm the new settings by echoing them. However, the settings can be checked with the command ?<cr>.

Settings

.BAUD Setting the Baud Rate

```
.BAUD.xxxx<cr>
```

xxxx = baud rate (1200 ... 19200)

Example:

```
.BAUD.9600<cr>     (commands invisible)  
.RESET<cr>
```

NOTE

To activate the new settings, please remember to reset the barometer with the command `.RESET<cr>`

Setting the Serial Communication Parameters

The following parameter combinations are available with the PTB210 digital barometers. The factory setting for the parameters is E71.

```
.E71<cr>
```

or

```
.O71<cr>
```

or

```
.N81<cr>
```

The command sets the serial communication parameters of either a single barometer or all the barometers in.

NOTE

To activate the new settings, please remember to reset the barometer with the command `.RESET<cr>`

.ID Setting a Identification Code

```
.ID.xxx<cr>
```

xxx = identification code (max. 15 characters)

If there are several barometers on same line, it is necessary to use the ID -code in order to direct the command for a specific instrument.

NOTE

As default, the ID code is 0. When several barometers will be used on same line, the codes have to be set before hand separately for each instrument.

The barometer handles the ID-code as characters i.e. 0001, 01 and 1 are different codes

Setting Pressure Limits

If desired a lower and a higher pressure limits can be given to the barometer. The limits can be used to define e.g. the calibrated pressure range to a host system.

```
.PMIN.xxxx<cr>
```

xxxx = lower pressure limit (0 ... 15000 hPa)

If current pressure is under the limit, the barometer outputs ****.** in stead of the pressure reading.

```
.PMAx.xxxx<cr>
```

xxxx = higher pressure limit

If current pressure is over the limit, the barometer outputs ****.** in stead of the pressure reading

NOTE

To activate the new settings, please remember to reset the barometer with the command .RESET<cr>

.MPM Measurements per Minute

```
.MPM.xxx<cr>
```

xxx = number of measurements per minute (6 ... 4200)

The command sets the number of measurements performed in one minute. As default, the MPM is 60.

$60 \text{ min}^{-1} = 1 \text{ s}^{-1} = 1 \text{ measurement per second}$

NOTE

To activate the new setting, please remember to reset the barometer with the command `.RESET<cr>`

.AVRG Defining the Averaging

```
.AVRG.xxx<cr>
```

xxx = the number of measurements of which the average is calculated (0 ... 255). As default, the AVRГ is 0.

The command sets the number of measurement points that are used for the calculating an average pressure reading. However, this is not a moving average.

An example: if the number of measurements per minute is set to 30, and the averaging to 5, the pressure reading is updated every 10 seconds.

NOTE

To activate the new setting, please remember to reset the barometer with the command `.RESET<cr>`

.PD Setting the Instrument to Power Down State

```
.PD<cr>
```

The command sets the barometer to power down state in which it does not measure the pressure. The instrument is re-activated by pressing the enter-key. After this, the barometer settles in a half of a second. Then any command can be given to the barometer.

Operating Commands

.P Outputting One Single Message

.P<cr>

The command outputs the latest multi-point corrected pressure reading with two decimals.

```
.P<cr>          (command invisible)
1012.99
```

.BP Continuous Outputting

.BP<cr>

The command outputs the MPC corrected pressure reading continuously. The output interval depends on the measurement rate and the averaging. The outputting is stopped by pressing enter key (<cr>).

```
.P<cr>          (command invisible)
997.99
998.01
998.01
...
998.02
<cr>           (command invisible)
```

.UNIT Selecting a Pressure Unit

.UNIT.x<cr>

x = 0	(hPa)	6	(kPa)
1	(mbar)	7	(Pa)
2	(inHg)	8	(mmH ₂ O)
3	(psia)	9	(inH ₂ O)
4	(torr)	10	(bar)
5	(mmHg)		

As default, the unit is 0.

NOTE

To activate the new setting, please remember to reset the barometer with the command `.RESET<cr>`

Output with or without the Unit

```
.FORM.0<cr>
```

The command cancels the outputting of the unit after pressure reading. This is also the factory setting for the output format.

1017. 61

```
.FORM.1<cr>
```

The command adds the unit to the outputting. The standard output field is for 6 characters. The first character is always a space.

1017. 61 hPa

NOTE

To activate the new setting, please remember to reset the barometer with the command `.RESET<cr>`

.RESET Resetting the Instrument

```
.RESET<cr>
```

The command resets the barometer and activates the setting changes.

Setting the Pressure Corrections On/Off

These commands are used to set multi-point corrections either on or off. See also the chapter Calibration and Adjustment on page 21.

```
.MPCON<cr>
```

The command activates the multi-point corrections.

```
.MPCOFF<cr>
```

The command deactivates the multi-point corrections.

NOTE

To activate the new setting, please remember to reset the barometer with the command `.RESET<cr>`

.CALD Setting the Calibration Date

With this command, the last calibration date can be stored in the memory of the barometer.

.CALD.xxx

xxx = calibration date; max. 15 characters

Example:

.CALD.991015<cr>

Setting the RS485 Terminating Resistor On/Off

The PTB210 series barometers have a built-in RS485 terminating resistor, which is set, as default, OFF. The resistor can be set either ON or OFF with the .ROFF/.ROFF commands. If the barometer is in the end of the serial line, the resistor should be set ON, especially, when long cables are used.

In case several barometers are connected to same line, only the resistor of the last one is set ON, with the others it should be OFF. This prevents formation of excessive load on the line. The maximum amount of barometers on same line is 32.

At the end of the serial bus there must be a PTB210 barometer, a dynamic line adapter or a line master (see figure below).

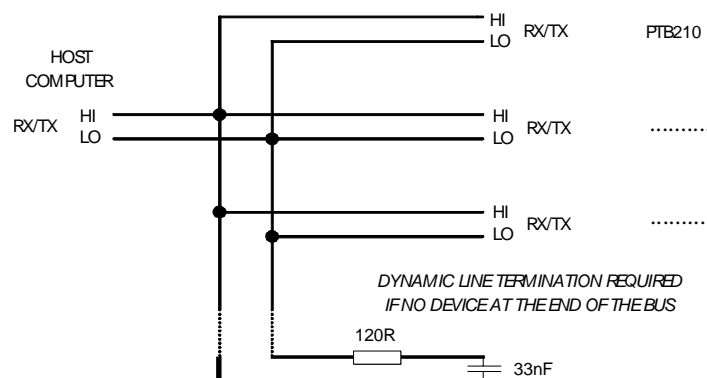

.RON<cr>

The .RON command sets the terminating resistor on.

.ROFF<cr>

The .ROFF command sets the terminating resistor off.

Self-Testing

.? Basic Information of the Barometer Settings

.?<cr>

The command lists the basic information of the barometer settings. The following example shows also the factory settings for 50...1100 hPa model.

```
.?<cr>                (command not visible)
PTB210 Ver 1.0
CAL DATE      :1999-06-10
ID CODE      :10
SERIAL NUMBER :T00100004
MULTIPOINT CORR:ON
MEAS PER MINUTE: 60
AVERAGING    : 0
PRESSURE UNIT : hPa
Pressure Min...Max: 500 1100 (50 1100 for model 50...1100)
LOW CURRENT MODE
RS485 RESISTOR OFF
```

CHAPTER 5

CALIBRATION AND ADJUSTMENT

The PTB210 series digital barometers can be fine adjusted and calibrated against pressure standards that have high accuracy and stability as well as known traceability to international standards. For the Class A barometers, standards with uncertainty of ± 70 ppm (± 2 standard deviation value) or better should be used. For the Class B barometers, electronic working standards with uncertainty of ± 150 ppm are recommended.

NOTE

Calibration is considered not to involve any adjustments.

The pressure readjustment of a PTB210 series digital barometer is performed by deactivating first the multi-point corrections using MPCOFF command. All fine adjustments are then deactivated. By comparing the output to a reference, the user can define the corrections required for readjustment.

It is advisable to write down the previous multi-point corrections so that they will not be lost by mistake.

The corrections are given by using the Wizard software; available for download at <http://www.vaisala.com/PTB210Wizard/>. When the new multi-point corrections have been entered to the barometer, the corrections are activated either with the Wizard or with the MPCON command. Finally, the barometer is calibrated to verify its real accuracy.

Wizard Software

The user-friendly Wizard software is designed to work in WIN3.X, WIN95, and NT environment. The multi-point pressure corrections for the PTB210 barometers are given through the serial line by using this program. Moreover, a few settings of the instrument can be changed using the Wizard.

Operation

First, check that the terminal software in use is closed before operating the Wizard.

NOTE

The Wizard uses either RS232 or RS485 interface. If the TTL level interface is used, disconnect the RXD/TXD wires and then connect the RX/TX wires (see page 12).

- To start the Wizard program in NT:
 1. Double-click the My Computer icon.
 2. Double-click the drive that contains the file.
 3. To start the program, double-click the WIZARD.EXE-file.

OR

- To start a program by using the Run command in NT
 1. Click Start, and then click Run.
 2. In the Open box, type the location and name of the program you want to start. Alternatively, browse the location, and choose the name of the program (WIZARD.EXE). Then, click OK.

PTB210 WIZARD 1.00

1. Choose the COM port in use from the file menu.
2. To open the connection click the **Read PTB210**-button.

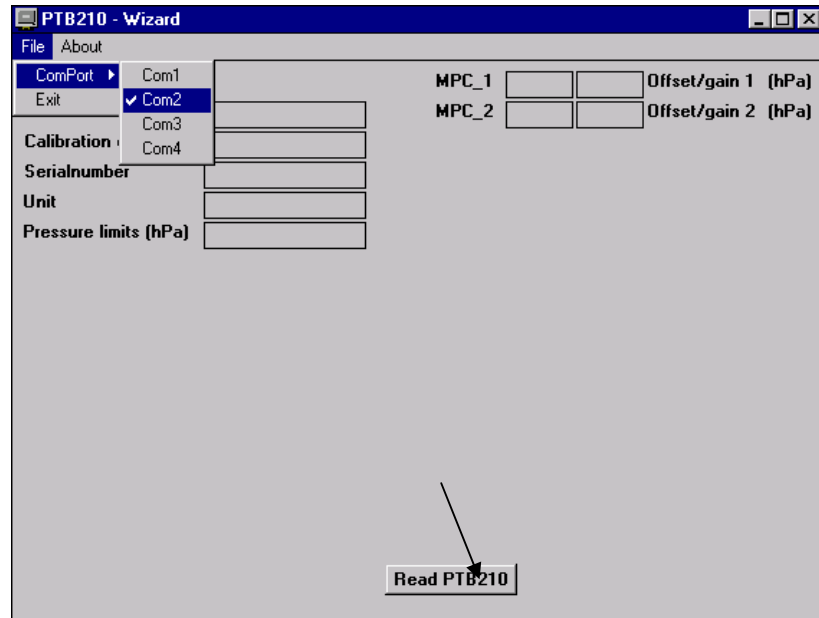

3. Give reference pressure values and the corresponding corrections. Calculate the corrections according to the following equation. The settings on left-hand side can also be changed.

$$CORR = P_{reference} - P_{measured} \quad (1)$$

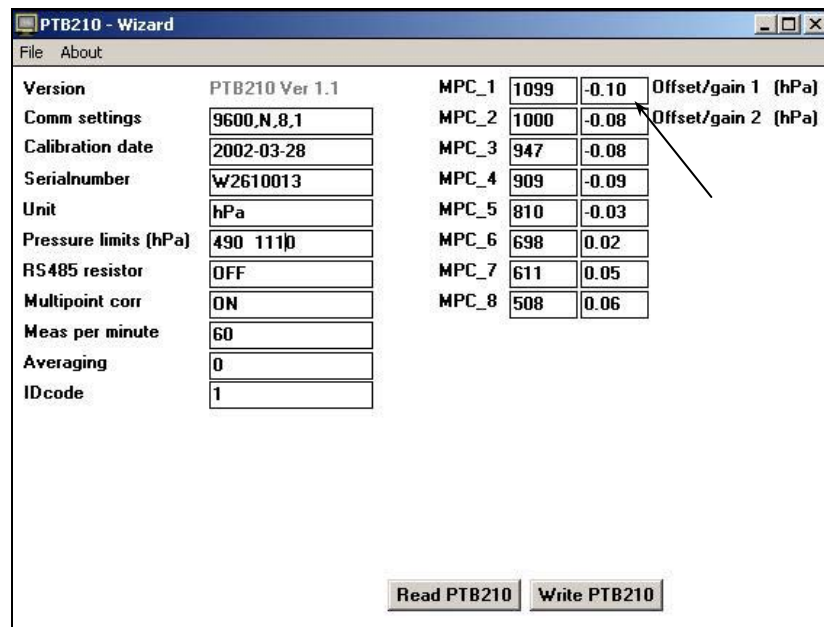

NOTE

The values are given in hPa: the reference value as whole number, and the correction with two decimals.

4. To save the new corrections, click the **Write PTB210**-button.
5. The program then asks a password. As default, no password exists. Just click **OK**. The password can be used to prevent saving of any new corrections without entering it. To give a password, click the **Change**-button.

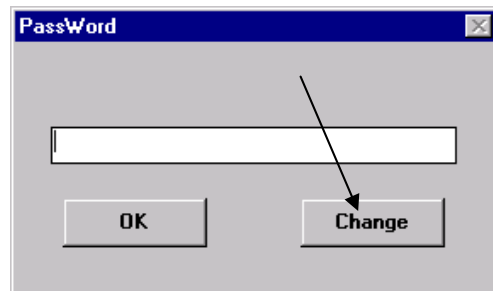

6. Enter a new password and confirm by re-entering it.

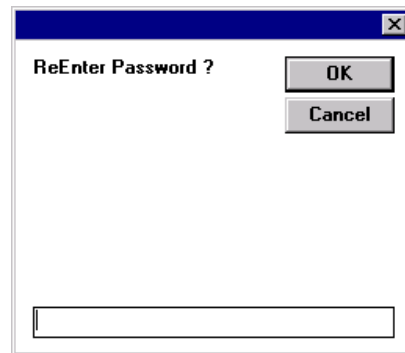
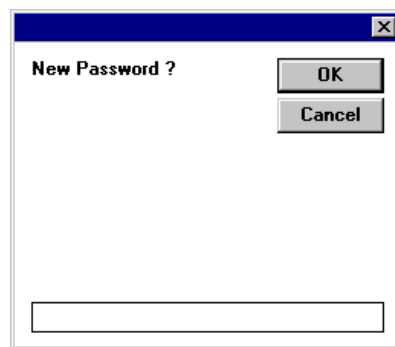

NOTE

Remember to set the MPC corrections on after given them.

CHAPTER 6

TECHNICAL DATA

Technical Specification

Operating Range

Pressure range	500 ... 1100 hPa
	50 ... 1100 hPa
Operating temperature range	-40 ... +60°C
Humidity range	non condensing

Accuracy

500...1100 hPa	Class A	ClassB
Non linearity*	± 0.10 hPa	± 0.15 hPa
Hysteresis*	± 0.05 hPa	± 0.05 hPa
Repeatability*	± 0.05 hPa	± 0.05 hPa
Calibration uncertainty**	± 0.07 hPa	± 0.15 hPa
Total accuracy (20°C)***	± 0.15 hPa	± 0.20 hPa
Temperature dependence (-40 ... +60°C)****	± 0.20 hPa	± 0.20 hPa
Total accuracy*** (-40 ... +60°C)	± 0.25 hPa	± 0.30 hPa
Long term stability	± 0.10 hPa/year	± 0.10 hPa/year
50...1100 hPa		
Non linearity*		± 0.20 hPa
Hysteresis*		± 0.10 hPa
Repeatability*		± 0.10 hPa
Calibration uncertainty**		± 0.20 hPa
Total accuracy (20°C)***		± 0.35 hPa
Temperature dependence (-40 ... +60°C)****		± 0.40 hPa
Total accuracy*** (-40 ... +60°C)		± 0.50 hPa
Long term stability		± 0.20 hPa/year

* Defined as the ± 2 standard deviation limits of end-point non-linearity, hysteresis error or repeatability error.

** Defined as ± 2 standard deviation limits of inaccuracy of the working standard including traceability to NIST.

*** Defined as the root sum of the squares (RSS) of end-point non-linearity, hysteresis error, repeatability error and calibration uncertainty at room temperature.

**** Defined as ± 2 standard deviation limits of temperature dependence over the operating temperature range.

General

Supply voltage	
with RS485	8 ... 18 VDC
with RS232C	5 ... 28 VDC
with RS232C/TTL	5 ... 28 VDC
	reverse polarity protected
Current consumption	
normal mode	< 15 mA (factory setting)
power down mode	< 0.8 mA
shutdown mode	0.2 mA
Shutdown	ON/OFF
Settling time at power up	2 s
Serial I/O (factory setting *)	RS232C
	RS232C /TTL (optional)
	RS485, non isolated (optional)
parity	none, even*, odd
data bits	7*, 8
stop bits	1*, 2
Baud rate	1200, 2400, 4800, 9600*, 19200
Response time	1 s*
Resolution	0.01 hPa (1 measurement/s)
	0.05 hPa (20 measurements/s)
Max. pressure	5 000 hPa abs.
Pressure connector	M5 (10-32) internal thread
Pressure fitting	barbed fitting for 1/8" I.D. tubing
Housing	
electronics	IP65
sensor	IP53
Housing material	PC plastic
Pressure connector	M5 (10-32) internal thread
Pressure fitting	barbed fitting for 1/8" I.D. tubing
Supply/output cable length	1, 2, 3, 5, or 10 m
Weight	
Instrument	110 g
Cable	28 g/m

Electromagnetic Compatibility

Electromagnetic compatability

EN61326-1:1997+ Am1:1998 +
Am2:2001 Generic environment

[CISPR16/22 class B, EN 61000-4-2, EN 61000-4-3, EN 61000-4-4, EN 61000-4-5, EN 61000-4-6]

Dimensions in mm (inches)

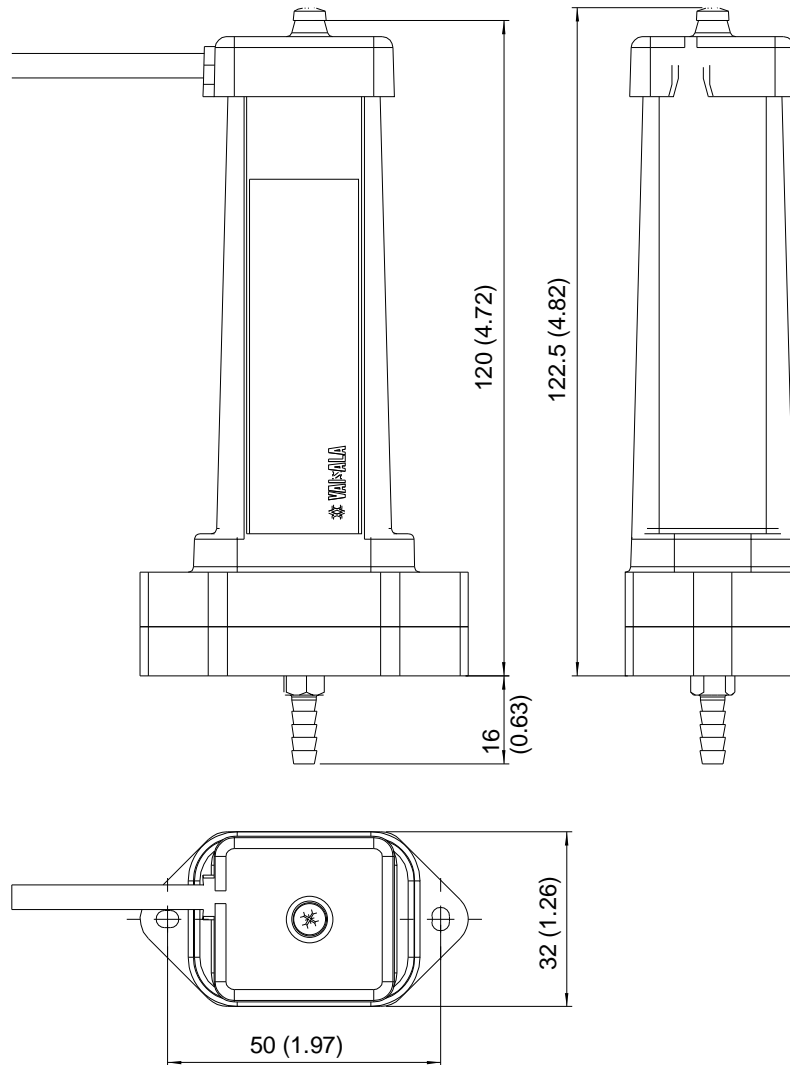

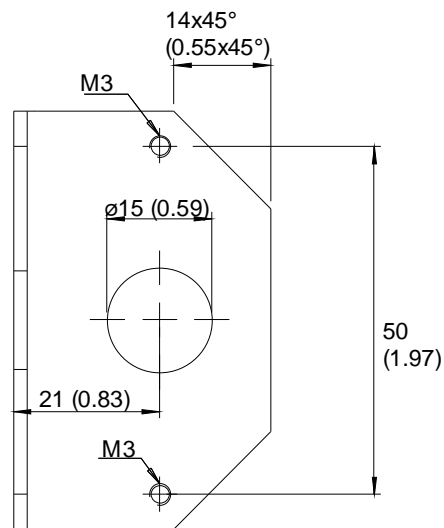
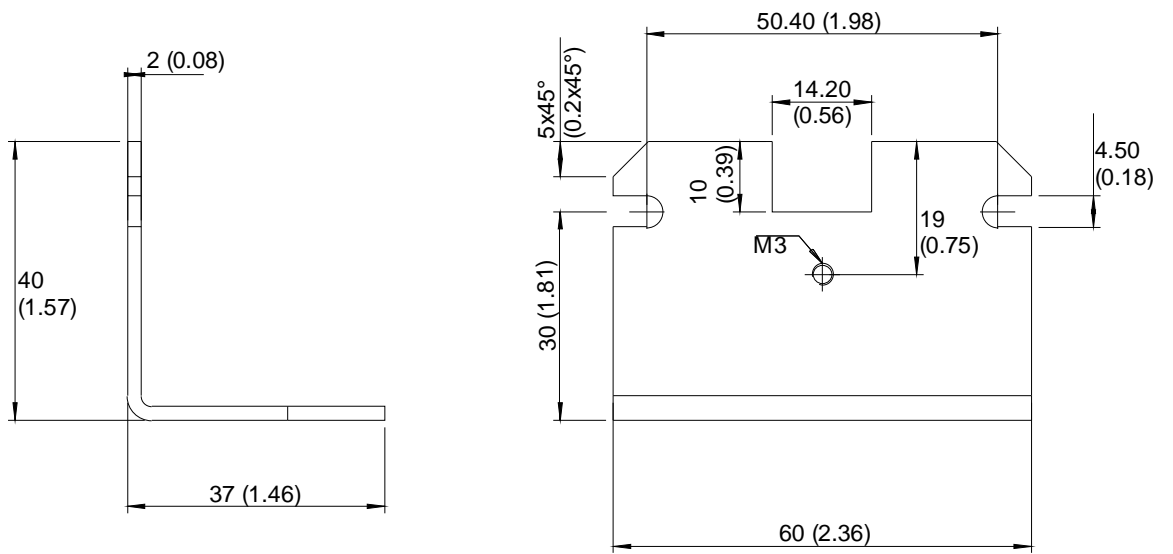



www.vaisala.com