

# USER'S GUIDE



## Digital Barometers with Analog Output PTB210 Series



PUBLISHED BY

Vaisala Oyj  
P.O. Box 26  
FIN-00421 Helsinki  
Finland

Phone (int.): +358 9 8949 1  
Fax: +358 9 8949 2227

Visit our Internet pages at <http://www.vaisala.com/>

© Vaisala 2006

No part of this manual may be reproduced in any form or by any means, electronic or mechanical (including photocopying), nor may its contents be communicated to a third party without prior written permission of the copyright holder.

The contents are subject to change without prior notice.

Please observe that this manual does not create any legally binding obligations for Vaisala towards the customer or end user. All legally binding commitments and agreements are included exclusively in the applicable supply contract or Conditions of Sale.

---

# Table of Contents

CHAPTER 1	
<b>GENERAL INFORMATION</b> .....	<b>3</b>
<b>Safety</b> .....	<b>3</b>
Feedback .....	3
<b>Recycling</b> .....	<b>4</b>
<b>Trademarks</b> .....	<b>4</b>
<b>License Agreement</b> .....	<b>4</b>
<b>Warranty</b> .....	<b>5</b>
CHAPTER 2	
<b>PRODUCT DESCRIPTION</b> .....	<b>7</b>
CHAPTER 3	
<b>INSTALLATION</b> .....	<b>9</b>
<b>Mounting</b> .....	<b>9</b>
Static Pressure Head .....	10
<b>Connections</b> .....	<b>11</b>
CHAPTER 4	
<b>CALIBRATION AND ADJUSTMENT</b> .....	<b>13</b>
<b>Wizard Software</b> .....	<b>13</b>
Operation .....	14
CHAPTER 5	
<b>TECHNICAL DATA</b> .....	<b>19</b>
<b>Technical Specifications</b> .....	<b>19</b>
Operating Range .....	19
Accuracy .....	19
General .....	20
Electromagnetic Compatibility .....	21
<b>Dimensions in mm (inches)</b> .....	<b>22</b>

## List of Figures

Figure 1	PTB210 and the Standard Accessories .....	7
Figure 2	The BAROCAP <sup>®</sup> Pressure Sensor .....	8
Figure 3	Different Mounting Options of the PTB210.....	9
Figure 4	Recommended Cable Position .....	10

## List of Tables

Table 1	Connections of the PTB210 Barometer with Analog Output ....	11
---------	---	----

# CHAPTER 1

## GENERAL INFORMATION

### Safety

Throughout the manual, important safety considerations are highlighted as follows:

**WARNING**

Warning alerts you to a serious hazard. If you do not read and follow instructions very carefully at this point, there is a risk of injury or even death.

**CAUTION**

Caution warns you of a potential hazard. If you do not read and follow instructions carefully at this point, the product could be damaged or important data could be lost.

**NOTE**

Note highlights important information on using the product.

### Feedback

Vaisala Customer Documentation Team welcomes your comments and suggestions on the quality and usefulness of this publication. If you find errors or have other suggestions for improvement, please indicate the chapter, section, and page number. You can send comments to us by e-mail: [manuals@vaisala.com](mailto:manuals@vaisala.com)

## Recycling

	Recycle all applicable material.
---	----------------------------------

	Dispose of batteries and the unit according to statutory regulations. Do not dispose of with regular household refuse.
---	---

## Trademarks

BAROCAP<sup>®</sup> is a registered trademark of Vaisala.

## License Agreement

All rights to any software are held by Vaisala or third parties. The customer is allowed to use the software only to the extent that is provided by the applicable supply contract or Software License Agreement.

## Warranty

Vaisala hereby represents and warrants all Products manufactured by Vaisala and sold hereunder to be free from defects in workmanship or material during a period of twelve (12) months from the date of delivery save for products for which a special warranty is given. If any Product proves however to be defective in workmanship or material within the period herein provided Vaisala undertakes to the exclusion of any other remedy to repair or at its own option replace the defective Product or part thereof free of charge and otherwise on the same conditions as for the original Product or part without extension to original warranty time. Defective parts replaced in accordance with this clause shall be placed at the disposal of Vaisala.

Vaisala also warrants the quality of all repair and service works performed by its employees to products sold by it. In case the repair or service works should appear inadequate or faulty and should this cause malfunction or nonfunction of the product to which the service was performed Vaisala shall at its free option either repair or have repaired or replace the product in question. The working hours used by employees of Vaisala for such repair or replacement shall be free of charge to the client. This service warranty shall be valid for a period of six (6) months from the date the service measures were completed.

This warranty is however subject to following conditions:

- a) A substantiated written claim as to any alleged defects shall have been received by Vaisala within thirty (30) days after the defect or fault became known or occurred, and
- b) The allegedly defective Product or part shall, should Vaisala so require, be sent to the works of Vaisala or to such other place as Vaisala may indicate in writing, freight and insurance prepaid and properly packed and labelled, unless Vaisala agrees to inspect and repair the Product or replace it on site.

This warranty does not however apply when the defect has been caused through

- a) normal wear and tear or accident;
- b) misuse or other unsuitable or unauthorized use of the Product or negligence or error in storing, maintaining or in handling the Product or any equipment thereof;
- c) wrong installation or assembly or failure to service the Product or otherwise follow Vaisala's service instructions including any repairs or installation or assembly or service made by unauthorized personnel not approved by Vaisala or replacements with parts not manufactured or supplied by Vaisala;
- d) modifications or changes of the Product as well as any adding to it without Vaisala's prior authorization;
- e) other factors depending on the Customer or a third party.

Notwithstanding the aforesaid Vaisala's liability under this clause shall not apply to any defects arising out of materials, designs or instructions provided by the Customer.

This warranty is expressly in lieu of and excludes all other conditions, warranties and liabilities, express or implied, whether under law, statute or otherwise, including without limitation any implied warranties of merchantability or fitness for a particular purpose and all other obligations and liabilities of Vaisala or its representatives with respect to any defect or deficiency applicable to or resulting directly or indirectly from the Products supplied hereunder, which obligations and liabilities are hereby expressly cancelled and waived. Vaisala's liability shall under no circumstances exceed the invoice price of any Product for which a warranty claim is made, nor shall Vaisala in any circumstances be liable for lost profits or other consequential loss whether direct or indirect or for special damages.

This page intentionally left blank.

## CHAPTER 2

# PRODUCT DESCRIPTION

The PTB210 series digital barometers are designed for various pressure ranges. The barometers with an analog output are available with different scalings between 500 ... 1100 hPa for 0 ... 5V or 0 ... 2.5V. The PTB210 series barometers are also available with a digital output.

The PTB210 series barometers offer an excellent solution for outdoor installations. They operate in a wide temperature range. The housing of the barometer electronics provides an IP65 standardized protection against sprayed water. The rugged corrosion-resistant housing in combination with the small size facilitates easy installation and a long lifetime for the barometer.

All the barometers are digitally adjusted and calibrated by using electronic working standards.

This manual gives the instructions for the use of PTB210 barometers with the analog output.

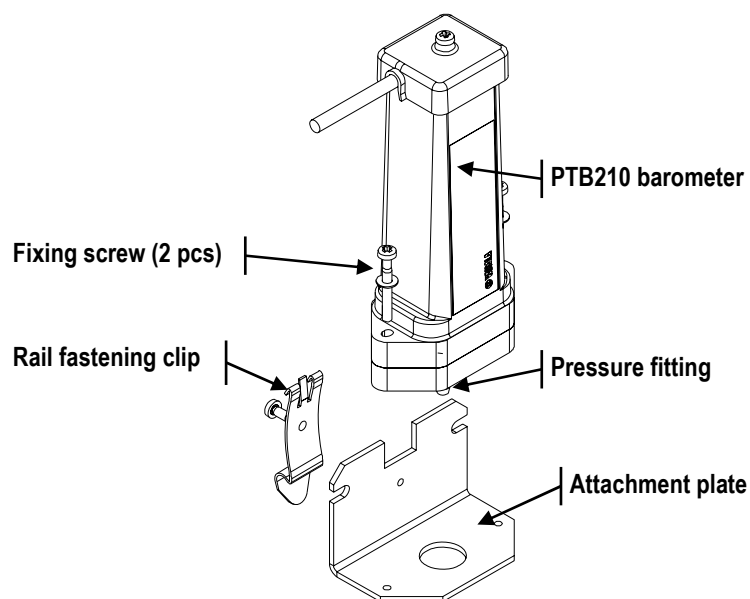

**Figure 1** PTB210 and the Standard Accessories

The PTB210 barometers incorporate the BAROCAP® silicon capacitive absolute pressure sensor developed by Vaisala. The sensor features excellent hysteresis and repeatability characteristics and has an outstanding temperature and long-term stability.

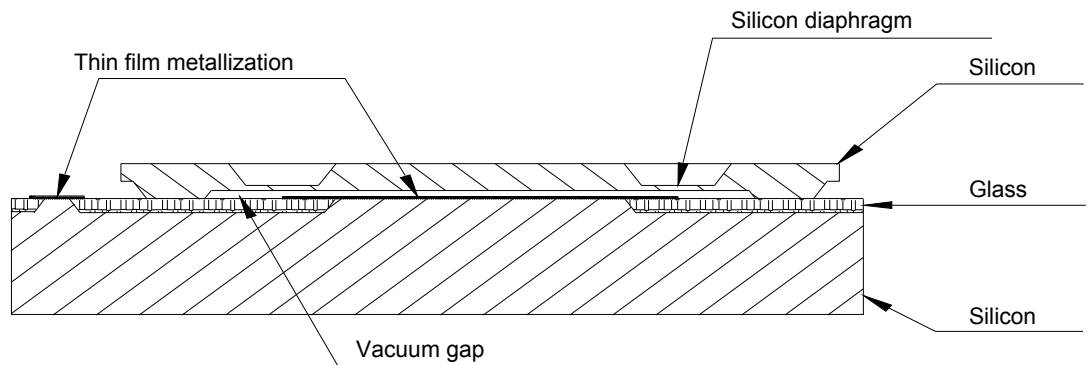

**Figure 2 The BAROCAP® Pressure Sensor**

The BAROCAP® pressure sensor consists of two layers of single crystal silicon having a layer of glass between them. The thinner silicon layer creates an integrated vacuum reference chamber, and forms a pressure-sensitive silicon diaphragm. The thicker silicon layer is the rigid base plate of the sensor, and it is clad with a glass dielectric. Thin film metallization has been deposited to form a capacitor electrode inside the vacuum reference chamber. The other electrode is the pressure-sensitive silicon diaphragm.

The coefficients of thermal expansion of silicon and glass materials used in the BAROCAP® pressure sensor are carefully matched together to minimize the temperature dependence, and to maximize the long-term stability. The BAROCAP® pressure sensor is designed to achieve zero temperature dependence at 1000 hPa, and its long-term stability has been maximized by thermal ageing at an elevated temperature.

## CHAPTER 3

# INSTALLATION

## Mounting

Due to the compact design of the PTB210, all you need to do is to mount the instrument, and to connect the wires. Use one of the following three mounting options.

- Remove the pressure fitting, and place the barometer on a desired structure. Then, fix it with the slot headed screws, the O-ring sealing the attachment (A).
- Fix the supplied attachment plate to a desired place with a screw by using the hole on the vertical part of the plate. Then, attach the barometer on the plate with the screws supplied (B).
- The PTB210 can also be placed to a standard rail (DIN 35) by using the attachment plate and clip (B). Fasten the clip and barometer to the plate with the screws supplied. Finally, attach the clip to a suitable rail.

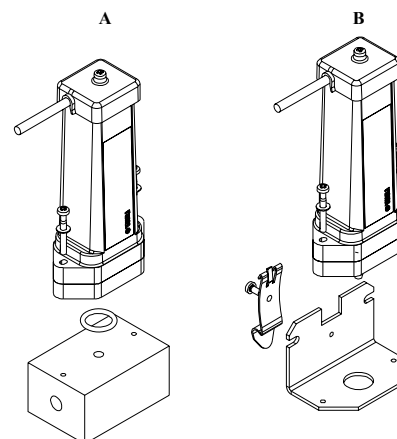

**Figure 3** Different Mounting Options of the PTB210

**NOTE**

Always place the barometer so that the pressure fitting is downwards.

**NOTE**

Check that the cable is not taken upwards from the barometer. This is to prevent water flowing along the cable, and gathering close to the feed-through.

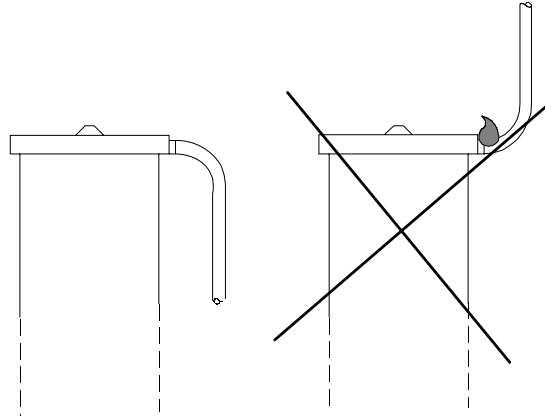

**Figure 4 Recommended Cable Position**

The IP65-classified housing enables the barometer to be mounted outdoors without any additional protection. However, please take care that rainwater cannot plug the open pressure fitting. In such conditions, it is recommended to connect a piece of a tube with inner diameter of 4 mm or more to the fitting. It is also possible to use a static pressure head, SPH10/20, which protects the pressure channel from rain, and minimizes the effect of wind.

## Static Pressure Head

Please note that the pressure fitting supplied with the transmitter is not a static pressure head, and that the transmitter cannot be used successfully as such in turbulent or high-speed static wind conditions. In demanding wind conditions, it is recommended to use Vaisala's static pressure head, SPH10/20, to which the PTB210 digital barometers can be directly integrated. This combination provides for accurate measurement in all wind conditions.

## Connections

Connect the wires of the PTB210 barometer according to Table 1. Use the pink wire for the supply voltage (8 ... 18 VDC), and the blue wire for grounding. The output signal is read from the white wire and grounded with the brown wire.

The gray and green wires are used to connect the barometer to PC when using the calibration Wizard software, or to Vaisala PMI20 digital barometer display. As a ground, use the blue wire.

If an external power control is used, its signal wire is connected to the yellow wire.

It is recommended to isolate the free wire ends.

**Table 1**      **Connections of the PTB210 Barometer with Analog Output**

Wire color	Signal
Grey	RX
Green	TX
Blue	Ground
Pink	Supply voltage (8 ... 18 VDC)
Brown	V <sub>out</sub> ground
White	V <sub>out</sub>
Yellow	External power control (TTL level: 1 = off, 0 = on)

This page intentionally left blank.

## CHAPTER 4

# CALIBRATION AND ADJUSTMENT

The PTB210 series barometers can be fine adjusted and calibrated against pressure standards that have high accuracy and stability as well as known traceability to international standards. By comparing the output to a reference, the user can define the corrections required for readjustment.

**NOTE**

Calibration is considered not to involve any adjustments.

It is advisable to write down the previous corrections so that they will not be lost by mistake.

The corrections are given by using the Wizard software; available for download at <http://www.vaisala.com/PTB210Wizard/>. Finally, the barometer is calibrated to verify its real accuracy.

## Wizard Software

The user-friendly Wizard software is designed to work in WIN3.X, WIN95, and NT environment. The two-point pressure corrections for the PTB210 barometers are given through the serial line by using this program. The calibration date can also be changed using the Wizard.

## Operation

- To start the Wizard program in NT:

1. Double-click the My Computer icon.
2. Double-click the drive that contains the file.
3. To start the program, double-click the WIZARD.EXE-file.

OR

- To start a program by using the Run command in NT

1. Click Start, and then click Run.
2. In the Open box, type the location and name of the program you want to start. Alternatively, browse the location, and choose the name of the program (WIZARD.EXE). Then, click OK.

### ***PTB210 WIZARD 1.00***

1. Choose the COM port in use from the file menu.
2. To open the connection click the **Read PTB210**-button.

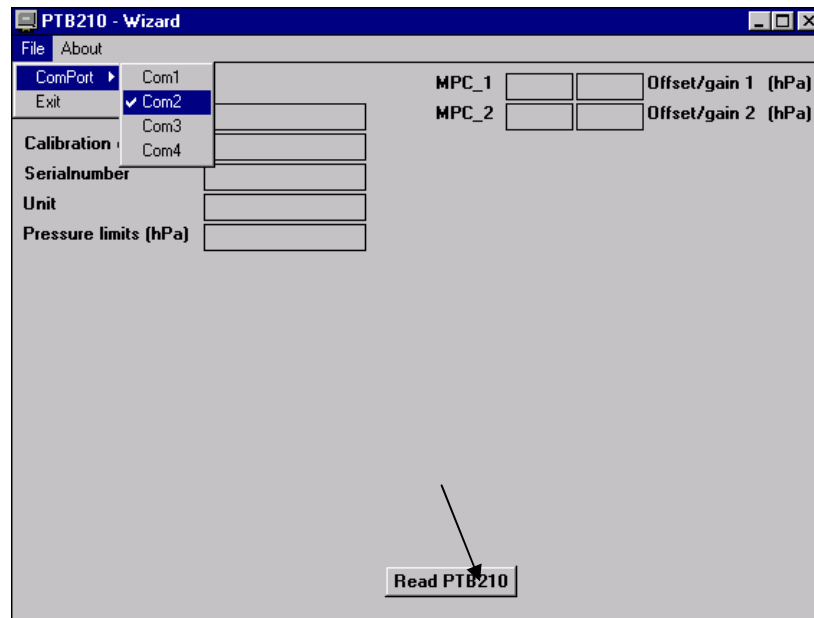

3. Give reference pressure values and the corresponding corrections.  
Calculate the corrections according to the equations below.

**NOTE**

Because the lower end of voltage output is not exactly 0 V, use as lower calibration point a value approximately 40 mV above the lower end limit. Thus with scale 600...1060 hPa and 0...5V output the lowest calibration point will be 604 hPa.

$$P_{measured} = P_{min} + \frac{U_{out} * (P_{max} - P_{min})}{U_{out max}} \quad (1)$$

$$corr_{new} = (P_{reference} - P_{measured}) + corr_{previous} \quad (2)$$

**Example** to calculate the higher end correction:

Barometer scale 600...1060 hPa with the 0...5V output.

- Output reading 4.8887 V
- $P_{measured} = 600 + [4.8887 * (1060-600)]/5 = 1049.76$  hPa
- Reference value 1050 hPa
- Previous correction 0.22 hPa

$$\implies \text{New correction } (1050 - 1049.76) + 0.22 = 0.46 \text{ hPa}$$

**NOTE**

The previous corrections have to be added to the new ones (see the example above).

The correction at the lower end is calculated in similar way. The new calibration date can also be given.

The values are given in hPa: the reference value as whole number, and the correction with two decimals.

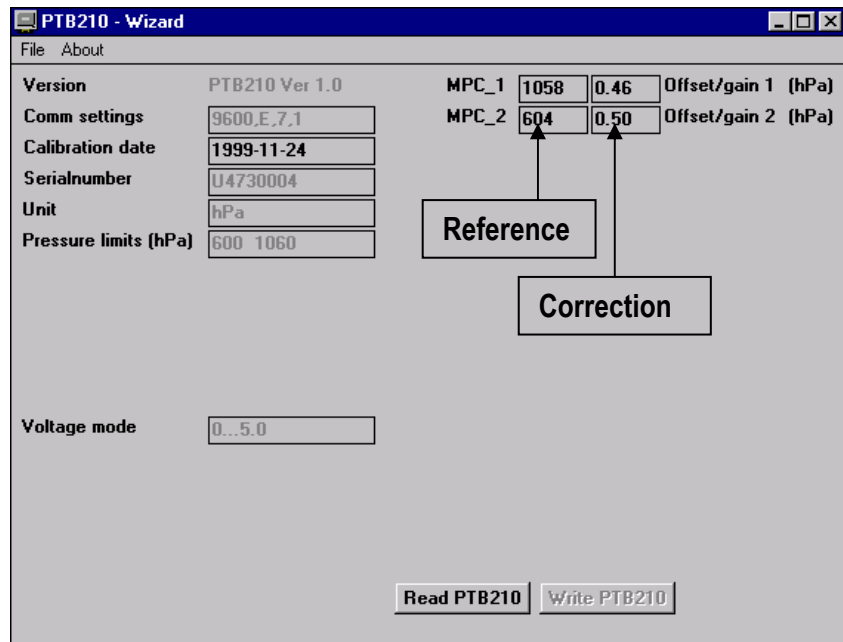

4. To save the new corrections, click the **Write PTB210**-button.

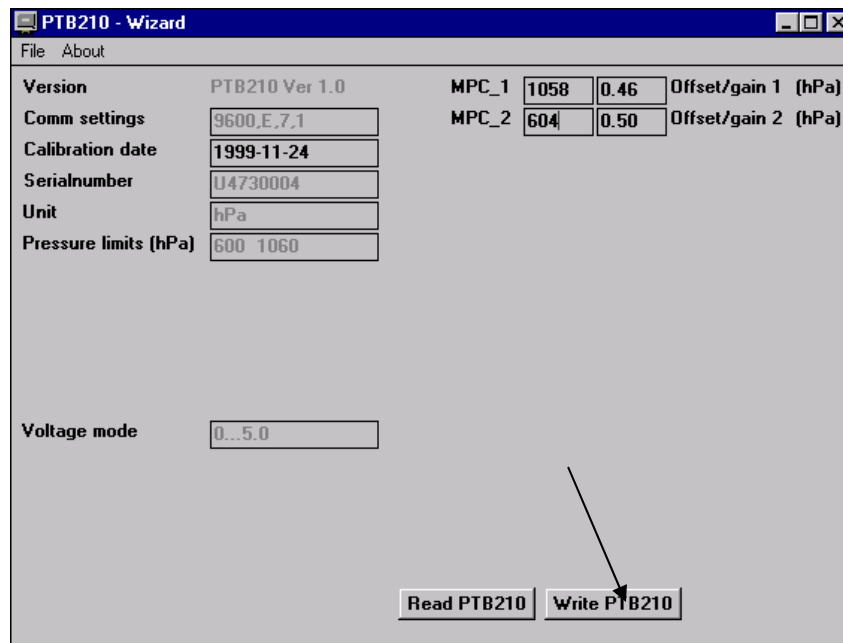

5. The program then asks a password. As default, no password exists. Just click **OK**. The password can be used to prevent saving of any new corrections without entering it. To give a password, click the **Change**-button.

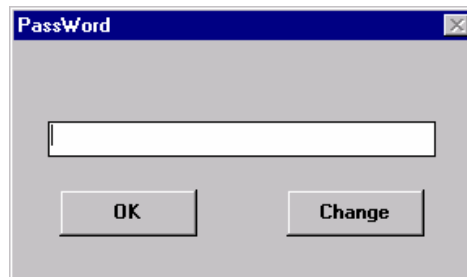

6. Enter a new password and confirm by re-entering it.

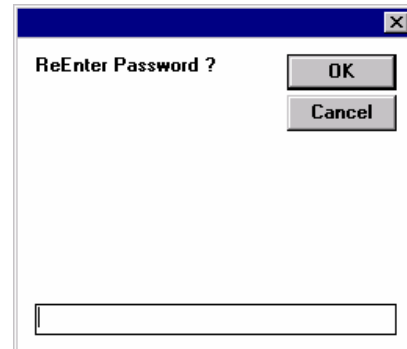
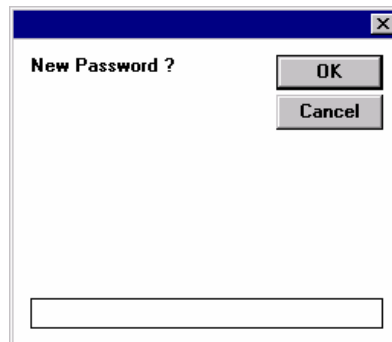
**NOTE**

Remember to set the MPC corrections on after given them.

This page intentionally left blank.

## CHAPTER 5

# TECHNICAL DATA

## Technical Specifications

### Operating Range

Pressure range (order specified)	500 ... 1100 hPa 800 ... 1060 hPa 600 ... 1060 hPa 900 ... 1100 hPa
Operating temperature range	-40 ... +60°C
Humidity range	non condensing

### Accuracy

Non linearity*	± 0.20 hPa
Hysteresis*	± 0.05 hPa
Repeatability*	± 0.05 hPa
Calibration uncertainty**	± 0.15 hPa
Total accuracy (20°C)***	± 0.30 hPa
Temperature dependence (-40 ... +60°C)****	± 0.50 hPa
Total accuracy*** (-40 ... +60°C)	± 0.60 hPa

Long term stability  $\pm 0.10$  hPa/year

\* Defined as the  $\pm 2$  standard deviation limits of end-point non-linearity, hysteresis error or repeatability error.

\*\* Defined as  $\pm 2$  standard deviation limits of inaccuracy of the working standard including traceability to NIST.

\*\*\* Defined as the root sum of the squares (RSS) of end-point non-linearity, hysteresis error, repeatability error and calibration uncertainty at room temperature.

\*\*\*\* Defined as  $\pm 2$  standard deviation limits of temperature dependence over the operating temperature range.

## General

Outputs (order specified)	0 ... 5 VDC 0 ... 2.5 VDC
Supply voltage	8 ... 18 VDC reverse polarity protected
Current consumption	
normal mode	< 8 mA
shutdown mode	0.2 mA
Shutdown	ON/OFF
Response time	500 ms
Resolution	300 $\mu$ V
Measurement rate	3 measurement/s
Load resistance	>10 kohm (to ground)
Max. pressure	5 000 hPa abs.
Pressure connector	M5 (10-32) internal thread
Pressure fitting	barbed fitting for 1/8" I.D. tubing
Housing	
electronics	IP65
sensor	IP53
Housing material	PC plastic
Cable length	1, 2, 3, 5, or 10 m
Weight	
Instrument	110 g
Cable	28 g/m

## Electromagnetic Compatibility

Electromagnetic compatability EN61326-1:1997+ Am1:1998 +  
Am2:2001 Generic environment

[CISPR16/22 class B, EN 61000-4-2, EN 61000-4-3, EN 61000-4-4, EN 61000-4-5, EN 61000-4-6]



## Dimensions in mm (inches)

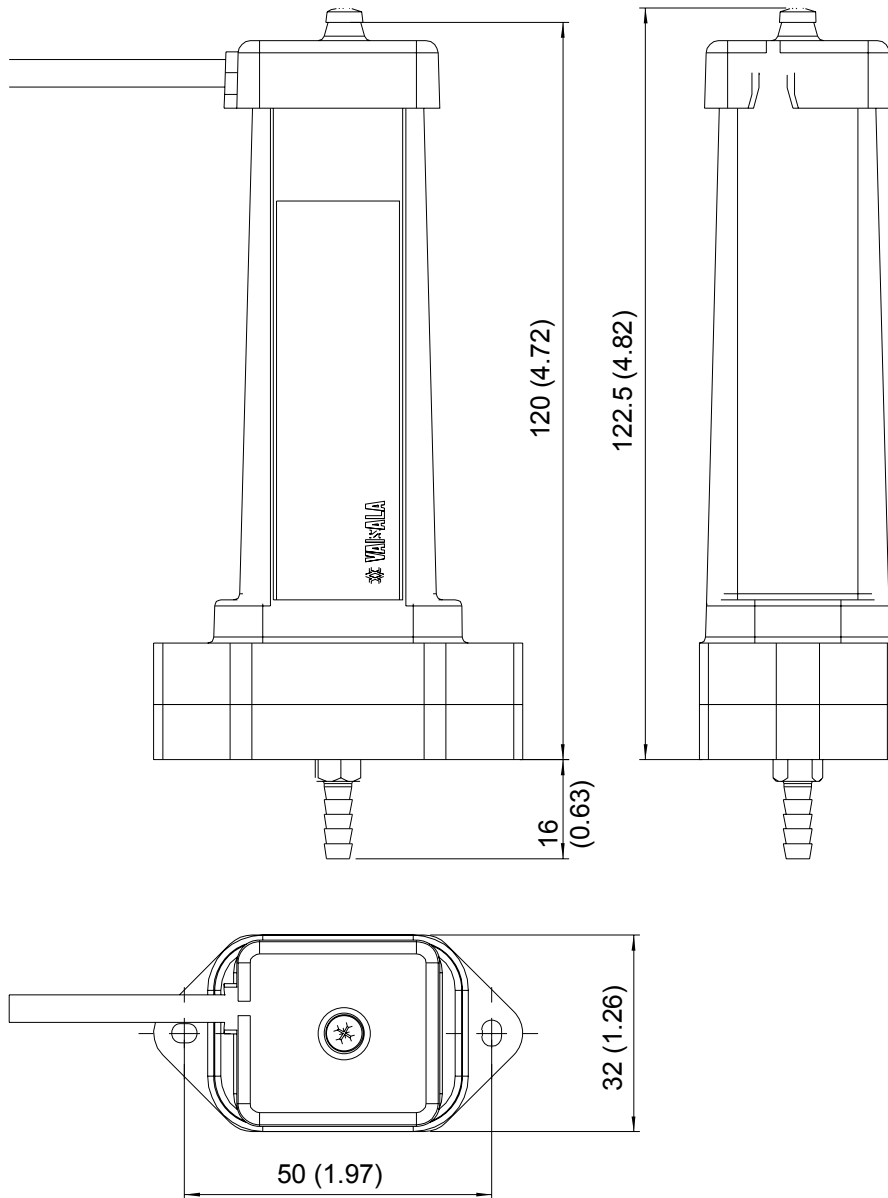

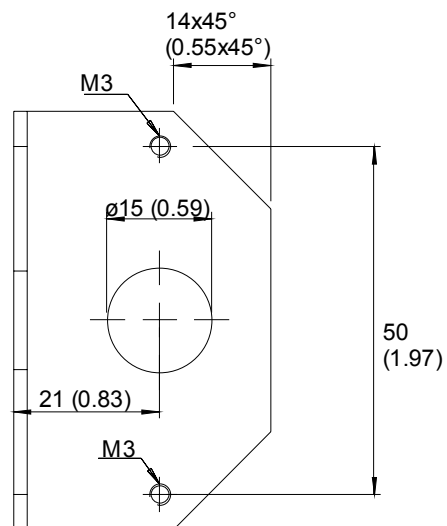
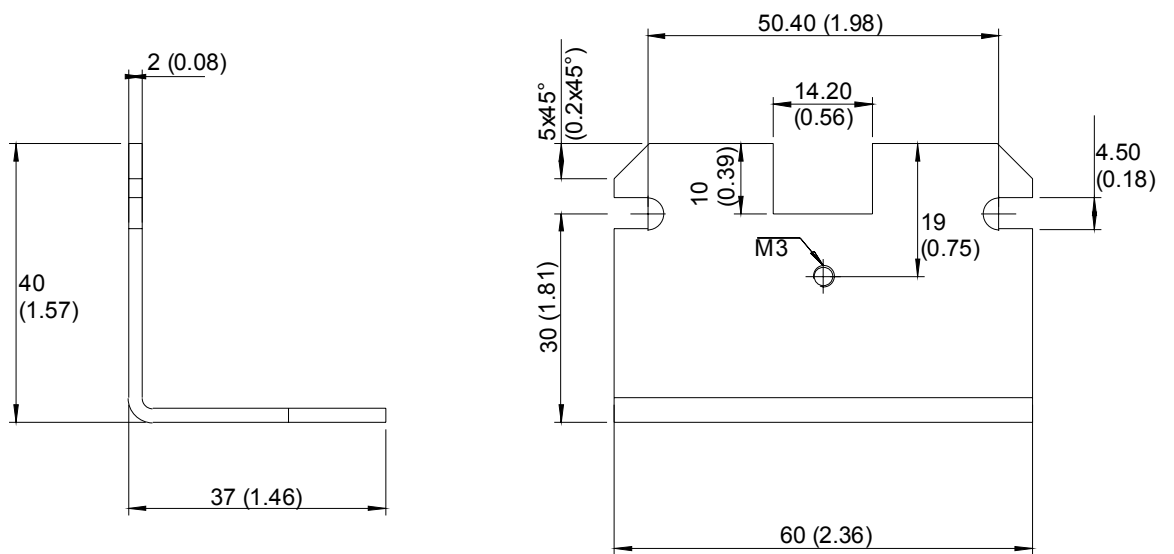



[www.vaisala.com](http://www.vaisala.com)